

Notes:

1. Concrete shall be 4000 PSI with 6% air entrainment
2. All anchor bolts shall be high strength Steel.
3. Rail Clips, Bolts, Nuts and washers shall be plated
4. All steel rail, end pieces and intermediate stops shall be primed with red oxide paint.
5. All component parts of the CMS system are interchangeable.
6. Maximum Loading 48,000# per Rack.

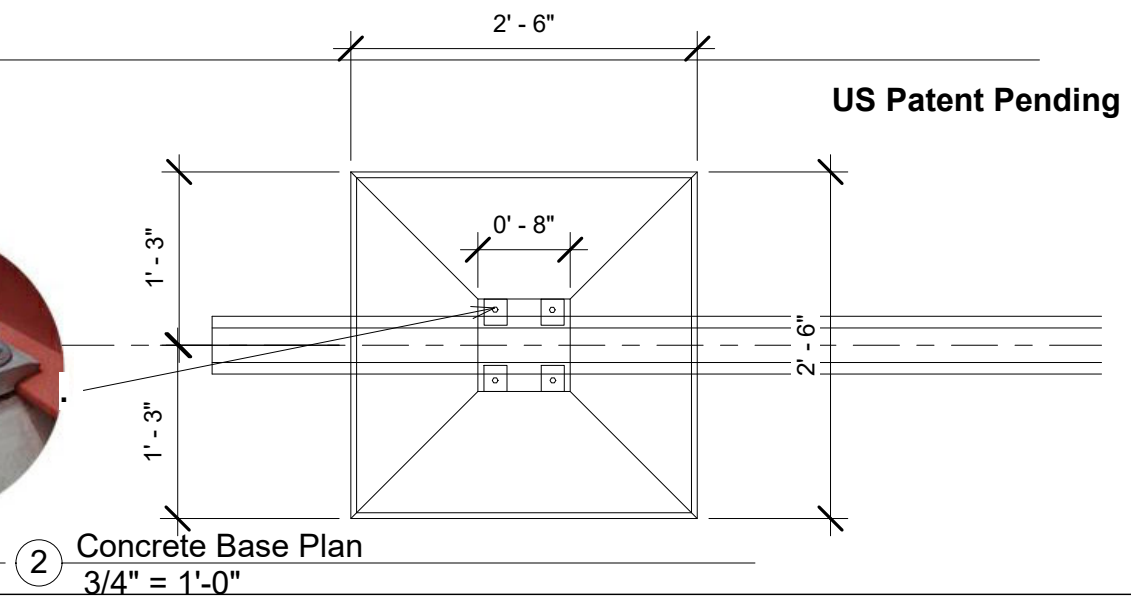
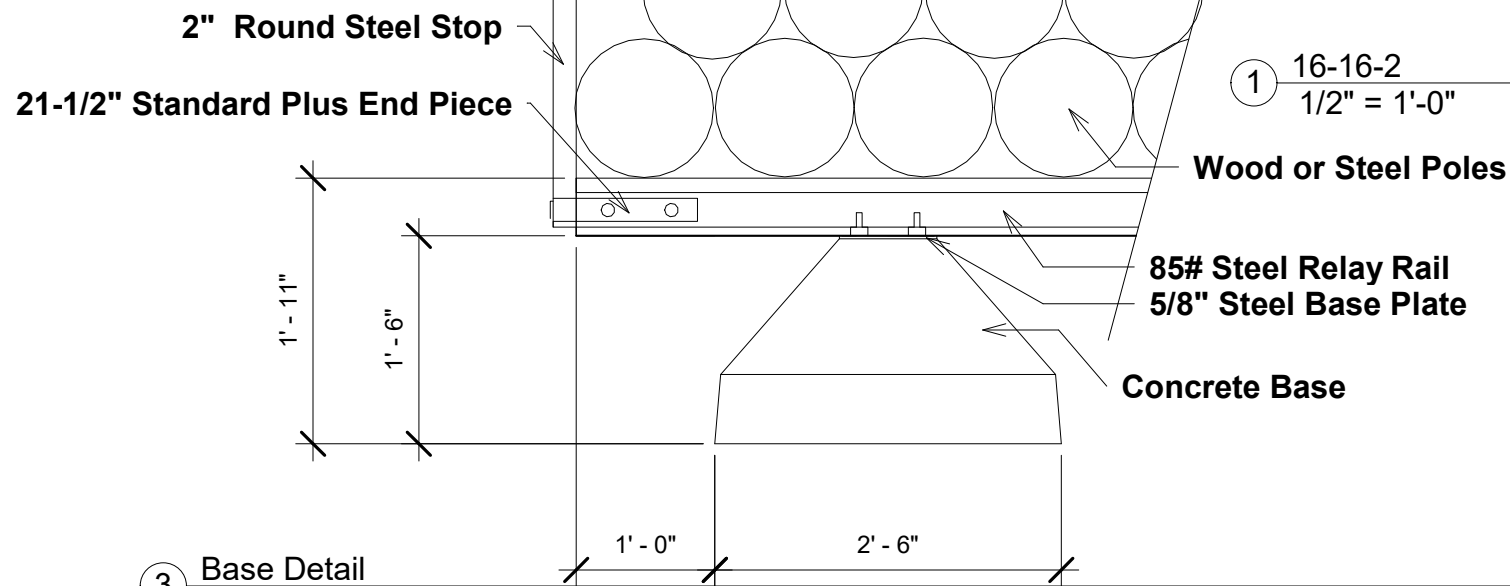
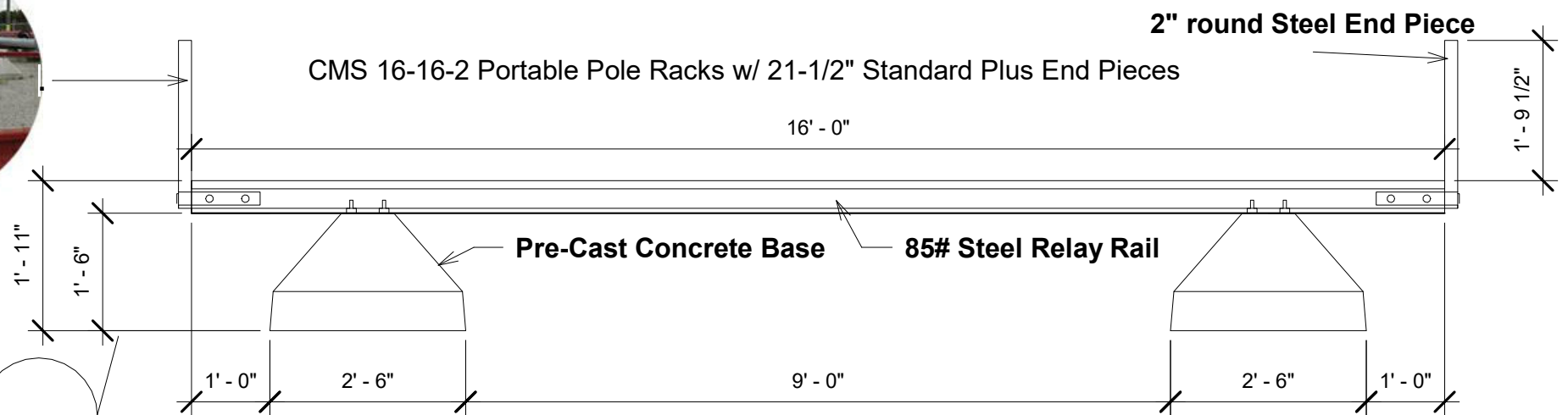
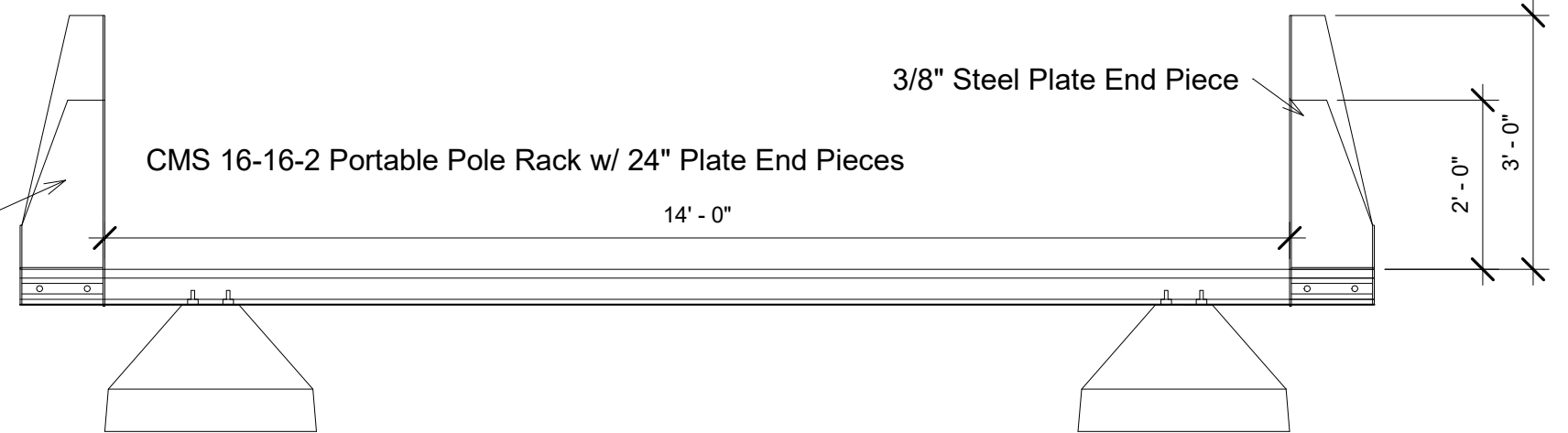

3 Base Detail
3/4" = 1'-0"

2 Concrete Base Plan
3/4" = 1'-0"



CMS Utility Services, Inc.
Special Design

No.	Description	Date

16-16-2 Portable Pole Rack		
Project number	Spec. Drawing	S-100
Date	December 10, 2024	
Drawn by	CMS	Scale As indicated
Checked by	Checker	