

Notes:

1. Concrete shall be 4000 PSI with 6% air entrainment
2. All anchor bolts shall be high strength Steel.
3. Rail Clips, Bolts, Nuts and washers shall be plated
4. All steel rail, end pieces and intermediate stops shall be primed with red oxide paint.
5. All component parts of the CMS system are interchangeable.
6. Maximum Loading 70,000# Per Rack.



CMS 24-24-3 Portable Pole Rack w/ 24" Plate End Pieces

3/8" Steel Plate End Piece

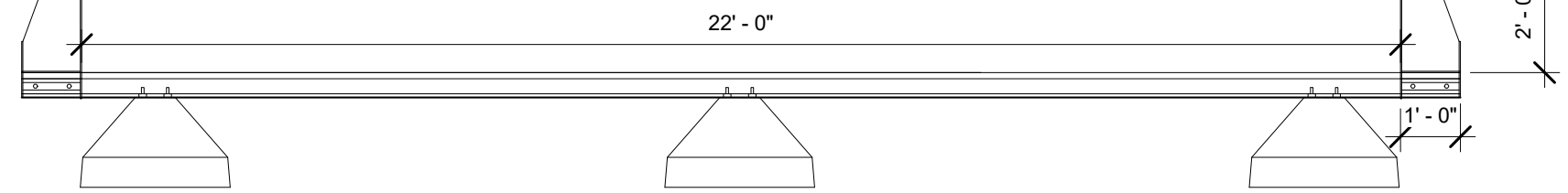

CMS 24-24-3 Portable Pole Rack w/ 21-1/2" Standard Plus End Piece

2" Round Steel End Piece

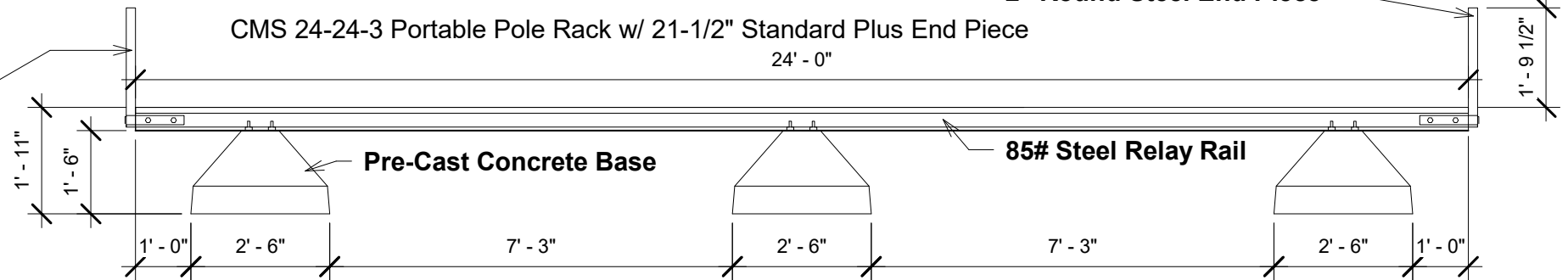

① 24-24-3
3/8" = 1'-0"

2" Round Steel Stop
21-1/2" Standard Plus End Piece

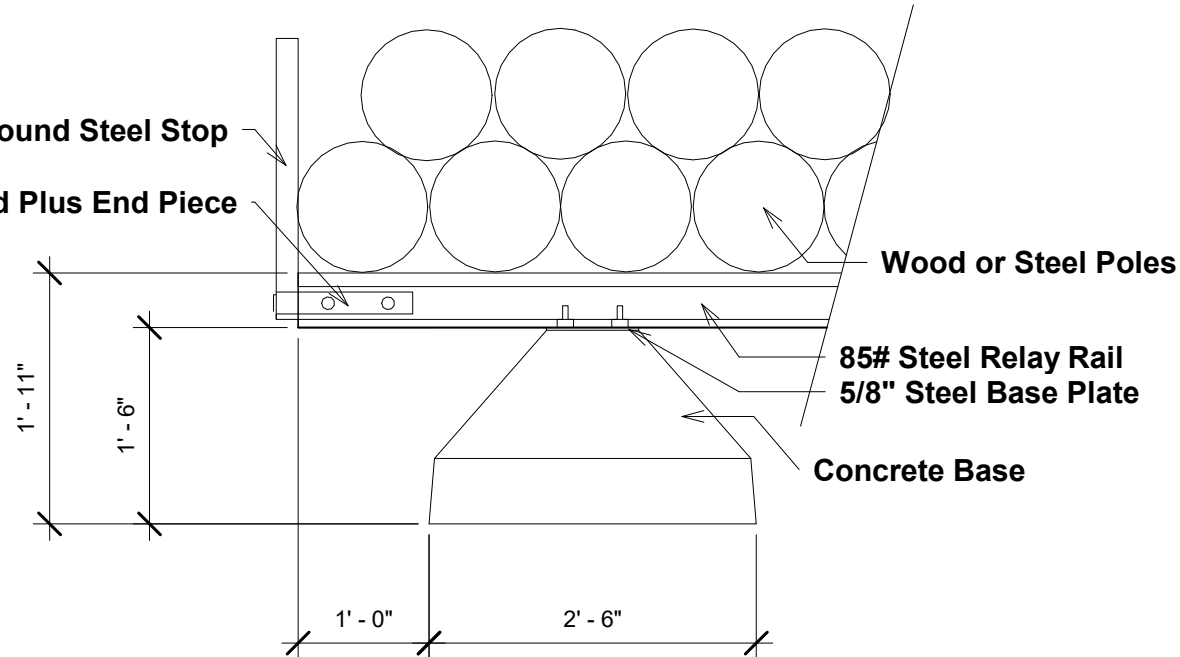

③ Base Detail Copy 3
3/4" = 1'-0"

US Patent Pending

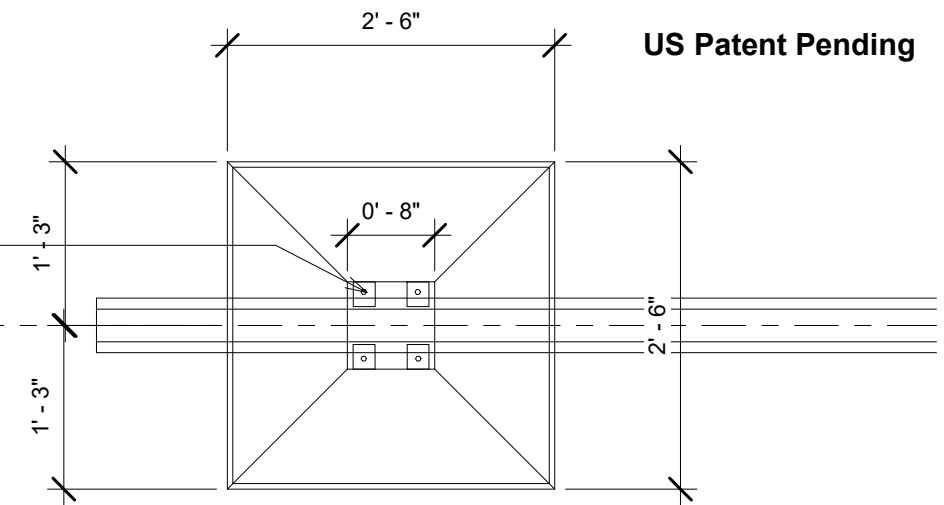

② Concrete Base Plan Copy 3
3/4" = 1'-0"

6959 Beech Grove Rd
Lebanon Junction, KY 40150
(502) 643-8785 Phone (866) 517-4472 Fax

199 Ferris Drive NW
Port Charlotte, FL 33952
(941) 743-7889 Phone (941) 866-5721

www.cmsus.com

CMS Utility Services, Inc.
Standard Spec Drawing

No.	Description	Date

24-24-3 Portable Pole Rack		
Project number	Spec. Drawing	S-103
Date	January 1, 2017	
Drawn by	CMS	Scale As indicated
Checked by	Checker	